

Email

DRM BSL CR

Fwd: Report of inquiry in the Accident on 02.06.23 at BNBR

From : GM Central railway <gm@cr.railnet.gov.in> Fri, Jun 30, 2023 01:34 PM
Subject : Fwd: Report of inquiry in the Accident on 02.06.23 at BNBR 📎 3 attachments
To : M S Uppal <cso@cr.railnet.gov.in>, PCSTE Central Railway <cste@cr.railnet.gov.in>, pcecr@rediffmail.com, Rajesh Arora <ce@cr.railnet.gov.in>, comcrgeneral@gmail.com, MUKUL JAIN <mmukul.jainn@gov.in>, DRM CR <drm@bb.railnet.gov.in>, DRM BSL CR <drm@bsl.railnet.gov.in>, DRM_NGP_CR <drm@ngp.railnet.gov.in>, DRM SUR C.R <drm@sur.railnet.gov.in>, DRMPA CR <drm@pa.railnet.gov.in>, drmbb@rediffmail.com, drmcrrngp@gmail.com, drmoffice2011@gmail.com, drmpune@gmail.com

From: "CRS S. E. Circle" <crssec@er.railnet.gov.in>
To: "GM ECoR" <gm@ecor.railnet.gov.in>
Cc: "GM SECR" <gm@secr.railnet.gov.in>, "GME.RLY ER" <gm@er.railnet.gov.in>, gm@nr.railnet.gov.in, "GM Central railway" <gm@cr.railnet.gov.in>, "GM NFR" <gm@nfr.railnet.gov.in>, "gmscr" <gm@scr.railnet.gov.in>, "General Manager NCRly" <gm@ncr.railnet.gov.in>
Sent: Thursday, June 29, 2023 10:05:18 AM
Subject: Fwd: Report of inquiry in the Accident on 02.06.23 at BNBR

From: "CRS S. E. Circle" <crssec@er.railnet.gov.in>
To: chiefcom@rediffmail.com
Sent: Thursday, June 29, 2023 7:19:18 AM
Subject: Report of inquiry in the Accident on 02.06.23 at BNBR

Sir,
The Report of the Statutory Inquiry in the accident of the Train No.12841 (Shalimar-Chennai Coromandal Express), the Goods Train No. N/DDIP, and the Train No. 12864 (SMVT Bengaluru-Howrah Express) at Bahanaga Bazar station on 02.06.2023, at about 18:56 hrs, in Kharagpur-Ranital section of Kharagpur Division in South Eastern Railway, is enclosed herewith.
As the size of the document is large, it is divided in the two parts; the Annexures are also sent in three parts in the subsequent mails.
A.M.Chowdhary
CRS/S.E.Circle

 **Forwarding Lr to CCRS_0001.pdf**
1 MB

 **Report Part II_0001.pdf**
7 MB

 **Report Part I_0002.pdf**
12 MB

VII. ANALYSIS

7.1 Inferences from Data-logger Report: -

7.1.1 Instantaneous change in the status of a point (Normal to Reverse, or Reverse to Normal), immediately after initiation of command for point-operation indicates faulty condition

7.1.1.1 It is observed from data logger report of BNBR station that the time taken from point-operation command to steady state indication on the Panel is 10-15 seconds. During these 10-15 seconds, flashing indication appears on the Panel to indicate that point is under operation. The point-indication on Panel becomes steady when point is properly set and locked at site; its detection relay picks up in the Centre-Relay Room, and in EI logic. This is normal behavior.

7.1.1.2 Contrary to this behavior, if point-operation time-period is insignificant, it should be inferred that there is a fault in point operation and its detection, i.e., the desired indication appears, but the physical status of the point does not move to the desired state.

7.1.1.3 The fault means that though the physical state of a point is Reverse or not fully Normal, but its Status in Relay room/EI logic, and on Panel is Normal; or vice-versa – this is very dangerous

7.1.2 Notes on the events logged in Data-logger from 15 hrs to 23:58 hrs on 02.06.23 (The Relay-State-Diagram on Annexure (xiii) may please be referred)

7.1.2.1 The Signal Route 1B (Up Home Signal to Up loop line with Crossover 17A/B Reverse), for the UP loop line, was initiated for reception of a train, and after its complete arrival, route was released at 15:00:42:875 hrs.

Note: Crossover 17A/B Reverse implies 17RWK1R Relay is picked up at the Central Relay Room, and 17RWKR logic bit is high in EI system.

7.1.2.2 After reception of this train, Crossover 17A/B was set to Normal from Reverse (Command at 15:01:05:281 hrs, and Crossover set to Normal at 15:01:19:656)

Note:

i. 17A/B Normal implies that the point at site is set to straight line(main line), 17NWKR picked up at the North Goomty, 17NWK1R Relay picked up at the Central Relay Room, and 17NWKR logic bit high in EI.

ii. This operation, from point-operation command to steady state indication, took about 14 seconds

7.1.2.3 Two trains were passed through UP main line from 15:05 hrs to 16:04 hrs.

7.1.2.4 Crossover 17 A/B was set to Reverse from Normal by initiation of Signal Route 1B (for UP loop line) at about 16:09 hrs and its route was released at about 16:13 hrs after reception of the train.

Note: Point operation command was generated through initiation of Signal Route 1 B (called auto route setting system)

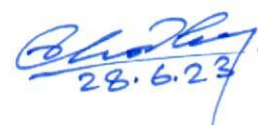
28.6.23

7.1.2.5 Crossover 17 A/B was set to Normal at 16:13:48 hrs with individual operation.

7.1.2.6 The Signal Route 1A (UP Home Signal to Up main line) was initiated at 16:20:11 hrs, but the Crossover 17A/B failed (17NWK1R Relay dropped automatically) before setting of the route.

Note: This was an unusual failure

7.1.2.7 The Signal Route 1A was cancelled, and the Crossover 17 A/B was set to Reverse with individual operation, and then command for individual operation, from Reverse to Normal, was initiated at 16:21:42:859 hrs; it took about 37 seconds for the point to get set to Normal (at 16:22:19:671 hrs)

Note: The point-operation time (37 seconds) was higher than the normal time of 13-14 seconds.

7.1.2.8 From 16:23 to 18:08 hrs, six trains were passed through the UP main line with Crossover 17 A/B Normal.

7.1.2.9 Then, by initiation of the Signal Route 1B for the Up-loop line, the Crossover 17 A/B moved from Normal to Reverse at 18:14:22:953 hrs.

Note: At this time both 17NWK1R and 17RWK1R Relays were in picked up state which was totally abnormal.

7.1.2.10 Thereafter one train was passed through UP loop line, and another train N/DDIP was received on the UP-loop line and controlled there.

Note: Though both 17NWK1R and 17RWK1R Relays were in picked up state, the Crossover 17 A/B at site was Reverse; only 17 RWKR logic bit was high.

7.1.2.11 After complete reception of the Goods train No. N/DDIP, the Route 1B was released at 18:34:52:968 hrs.

7.1.2.12 Command was given for individual operation of the Crossover 17 A/B (from Reverse to Normal), for which the command-relay 17WNR picked up at 18:34: 59:265 hrs, and Normal Indication logic bit 17NWK1R also picked up in EI at the same time, i.e., 18:34:59:265 hrs.

Note: Change in status from Reverse to Normal, within no time, indicates that Crossover 17A/B did not move from Reverse to Normal at site, and immediate appearance of Normal Indication indicates abnormal situation.

7.1.2.13 17 NWK1R Relay dropped automatically. Then 17RWK1R Relay also dropped, and subsequently 17NWK1R Relay again picked up automatically. These events took place in 2:375 seconds.

Note: These events are also unusual. With these events, it would not be possible to predict actual status of the Crossover 17A/B at site.

7.1.2.14 Through Green signals (Advanced Starter, Main Line Starter, Home, and Distant Signals Green) were taken off for passing the Train 12841 through UP main line where the UP Home Signal turned to green at 18:53:21:078 hrs.

Note: Though 17NWK1R Relay and 17NWK1R logic bit in EI were in picked up state, the actual status of Crossover 17A/B was not known (cannot be predicted).

- 7.1.2.15 As the Train 12841 moved ahead of UP Home Signal, track circuits dropped in sequence from 1T1, 1T2, 16BT, 17T to 8AXT. UMT1 dropped later on.

Note: Train 12841 seemed to traverse towards UP loop line instead of UP main line with Crossover 17 A/B Reverse.

- 7.1.2.16 17NWK1R Relay was still in picked up state even after complete damage of point machines on account of the accident at around 18:55:52 hrs.

Note: The physical state of the Crossover 17 A/B at site was out of correspondence (delinked) with its indication relay 17NWK1R, and 17RWK1R was being fed through some other circuit/source.

- 7.1.2.17 17NWK1R Relay dropped, picked up and again dropped within a short-spell and remained dropped after 23:28:58:750 hrs.

Note: This was also an unusual occurrence, denoting possibility of human-intervention.

7.1.3 Events after the collision of the Train No.12841 with Goods Train N/DDIP

Events logged in data logger	Inference
UMTPR down at 18:55:55:546 hrs	Derailed coaches of Train 12841 fell down on the Up-Main line
10 RECR down at 18:55:55:953 hrs	Signal post S10 was broken
16NWK1R dropped at 18:55:57:984 hrs	Derailed coaches of Train 12841 damaged the crossover 16A/B
DMTPR picked up at 18:55:59:625 hrs	The last coach of Train 12864 cleared the DN main line berthing track
DMTPR down at 18:56:01:265 hrs	Derailed coaches of Train 12841 fell down on the DN-Main line. Another capsized coach of Train 12841 hit the rear two coaches of train 12864 which were between the DN main line Starter and DN Adv.Starter; and derailed/capsized them.

7.2 Analysis on facts, evidences and information obtained in inquiry proceedings

- 7.2.1 From the statement and deposition of the Loco Pilot, and as per the statement of Assistant Loco Pilot of Train No. 12841, it was understood that though the train had been given run-through signals (UP Advanced Starter Signal -Green, UP Main Line Starter Signal: Green, UP Home Signal: Green, and Distant Signals: Green) to pass over the Up main line at BNBR, the train entered the Up-loop line.

[Handwritten Signature]
28.6.23

- 7.2.2 The Joint-Report of the supervisors, and from site-inspection after the accident, it was noticed that the right-hand curved tongue rail of the point 17A was housed with the straight stock rail for turn-out setting, and there was sufficient gap between the left-hand tongue rail and the curved stock rail; the point was in Reverse (towards the UP loop line).
- 7.2.3 In the first sitting of the inquiry proceedings, SM and S&T staff mentioned the following: -
- 7.2.3.1 ELB-replacement work was being carried out at LC 94 near North Goomty at BNBR. Pre-disconnection works were completed outside and inside the North-Goomty.
- 7.2.3.2 Disconnection for this work was issued on 02.6.2023 at 16:20 hrs and Reconnection was given at 16:50 hrs on the same day. During this disconnection period, the LC-gate related old circuits were replaced with new circuits inside the North Goomty.
- 7.2.3.3 After reconnection, S&T staff were still working in the North Goomty for Road-User signal circuits.
- 7.2.3.4 In the above work, no modification was involved in the other circuits available in North Goomty, viz., point circuits, track circuits, signal circuits, etc.
- 7.2.3.5 Since Sliding Barrier circuits (standby arrangement for ELB of LC 94) were functional during the above disconnection, there was no restriction in taking off signals.
- 7.2.4 On cross-questioning during inquiry at later stages, Shri Amir Khan SSE/Sig/SFO, Shri Abinash Ranjan Mohanty Tech III/BNBR, Shri Pappu Kumar Tech I/BLS, and Shri A.K..Mohanta, SSE/Sig/Incharge brought out the following facts:
- 7.2.4.1 Even after the accident, all the S&T staff working at the North Goomty were confident that the accident was not due to ELB-work done by them.
- 7.2.4.2 After the accident, Shri A.K.Mahanta SSE/Sig/BLS(Incharge), who was at the accident site, came to know from the Test-Room that the indication of the Crossover 17A/B was still showing Normal even when the point machines of 17A and 17B, at the site, were completely damaged.
- 7.2.4.3 Then Shri Mahanta asked the S&T staff to check any mistake in the wiring of LC-94 in the North Goomty.
- 7.2.4.4 In the North Goomty, Shri Pappu Kumar checked the voltage at terminal F13 & F14, above which 17NWKR was written on CTR Rack-1, in presence of Shri Mahanta and Shri Amir Khan, and found no voltage, though at these terminals there should have been voltage for 17NWKR, as its indication was available in the Simulation-Video. Then he noticed that, on the cable side, no cable-core was connected; instead, 16 strand flexible wires were connected. He found that these wires, not visible from the front side, were drawn from back-side of the rack, and traced the other ends of the flexible

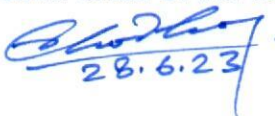
28.6.23

wires which were left disconnected from terminals F23 & F24 during the ELB wiring work.

Note:

- i. In the circuit of LC 79 of Balasore, which was being followed for the ELB-modification work of LC 94, there were two GFR circuits, viz. 2GF RR, and 3GF RR. The two numbers of GFR circuits were retained in accordance with the requirement of two Ground-Lever Frames (GF) Relays used in the earlier Mechanical Lifting Barrier arrangement.
- ii. At BNBR also, when Mechanical Lifting Barrier was in use, two numbers of GFR circuits, viz., GFR1, and GFR2 were used. Accordingly, the circuit names GFR1 at Terminals F21& F22, and GFR2 at Terminals F23&F24 were written on the CTR Rack-1, in the North Goomty. As shown in the completion wiring diagram, approved on 05.01.2015, only one GFR, viz., 26.2(GF)RR was used, which was allotted at terminal F21&F22 at both the Central Relay Room, and at the North Goomty. Terminals F23 & F24 were kept as spare. These changes were reflected in the Completion Wiring Diagrams, approved on 05.01.2015. However, the circuit names, GFR1 & GFR2, were not corrected on the terminal rack at the North Goomty.
- iii. In 2018, after meggering of 30 core cable between the Central Relay Room to the North Goomty, 17 NWKR circuit was shifted from F13, F14 to F23, F24 (which was spare at that time) by looping F13 to F23, and F14 to F24, with 16 strand flexible wires. However, this change was also neither reflected in the Completion Wiring diagrams, nor the circuit names corrected on the cable terminal rack at the North Goomty. An extract of the Cable Meggering Register is indicated in the following pictures: -

CABLE INSULATION STATION /										TEST REGISTER									
1 CORES: 30C					2 SIZE: 13.5mm					3 TYPE: SCREENED/UNSCREENED					4 DATE OF INSTALLATION / COMMISSION				
4 GRADE: 33KV					5 LOCATION: FROM 250 TO 300					6 NAME OF MANUFACTURER									
DATE	MONTH	YEAR	TEST	15	16	17	18	19	20	21	22	23	24	25	26	27	28	29	30
WEATHER CONDITION																			
1	15	10	100	100	100	100	100	100	100	100	100	100	100	100	100	100	100	100	100
2	15	10	100	100	100	100	100	100	100	100	100	100	100	100	100	100	100	100	100
3	15	10	100	100	100	100	100	100	100	100	100	100	100	100	100	100	100	100	100
4	15	10	100	100	100	100	100	100	100	100	100	100	100	100	100	100	100	100	100
5	15	10	100	100	100	100	100	100	100	100	100	100	100	100	100	100	100	100	100
6	15	10	100	100	100	100	100	100	100	100	100	100	100	100	100	100	100	100	100
7	15	10	100	100	100	100	100	100	100	100	100	100	100	100	100	100	100	100	100
8	15	10	100	100	100	100	100	100	100	100	100	100	100	100	100	100	100	100	100
9	15	10	100	100	100	100	100	100	100	100	100	100	100	100	100	100	100	100	100
10	15	10	100	100	100	100	100	100	100	100	100	100	100	100	100	100	100	100	100
11	15	10	100	100	100	100	100	100	100	100	100	100	100	100	100	100	100	100	100
12	15	10	100	100	100	100	100	100	100	100	100	100	100	100	100	100	100	100	100
13	15	10	100	100	100	100	100	100	100	100	100	100	100	100	100	100	100	100	100
14	15	10	100	100	100	100	100	100	100	100	100	100	100	100	100	100	100	100	100
15	15	10	100	100	100	100	100	100	100	100	100	100	100	100	100	100	100	100	100
16	15	10	100	100	100	100	100	100	100	100	100	100	100	100	100	100	100	100	100
17	15	10	100	100	100	100	100	100	100	100	100	100	100	100	100	100	100	100	100
18	15	10	100	100	100	100	100	100	100	100	100	100	100	100	100	100	100	100	100
19	15	10	100	100	100	100	100	100	100	100	100	100	100	100	100	100	100	100	100
20	15	10	100	100	100	100	100	100	100	100	100	100	100	100	100	100	100	100	100
21	15	10	100	100	100	100	100	100	100	100	100	100	100	100	100	100	100	100	100
22	15	10	100	100	100	100	100	100	100	100	100	100	100	100	100	100	100	100	100
23	15	10	100	100	100	100	100	100	100	100	100	100	100	100	100	100	100	100	100
24	15	10	100	100	100	100	100	100	100	100	100	100	100	100	100	100	100	100	100
25	15	10	100	100	100	100	100	100	100	100	100	100	100	100	100	100	100	100	100
26	15	10	100	100	100	100	100	100	100	100	100	100	100	100	100	100	100	100	100
27	15	10	100	100	100	100	100	100	100	100	100	100	100	100	100	100	100	100	100
28	15	10	100	100	100	100	100	100	100	100	100	100	100	100	100	100	100	100	100
29	15	10	100	100	100	100	100	100	100	100	100	100	100	100	100	100	100	100	100
30	15	10	100	100	100	100	100	100	100	100	100	100	100	100	100	100	100	100	100

Choudhary
28.6.23

12	"	100 V	100	100	> 100	> 200
13	17 NWKR	100 V	100	100	> 100	100 ←
14	"	100 V	100	100	> 100	> 200 ←
15	17 RWKR	100 V	100	100	> 100	> 200
16	"	100 V	100	100	> 100	> 200
17	GATE LKPR	100 V	100	100	> 100	
18	"	100 V	100	100	> 100	
19	GATE KTRKPR	100 V	100	100	> 100	
20	"	100 V	100	100	> 100	
21	GF (R1)	100 V	100	100	> 100	
22	"	100 V	100	100	> 100	
23	GF (R1)	100 V	100	100	> 100	> 200 ←
24	"	100 V	100	100	> 100	> 200 ←
25	16 ATPR	100 V	100	100	> 100	

- iv. Thus, 17NWKR circuit was running on the terminals F23&F24 which were marked as GFR2 on the cable terminal rack at the North Goomty.
- v. While carrying out the wiring work of the new ELB, the S&T staff had disconnected the existing wires at terminals F23&F24, and F21&F22, assuming GFR2, and GFR1 respectively, and rewired for new ELB accordingly.

This is depicted in the following picture: -

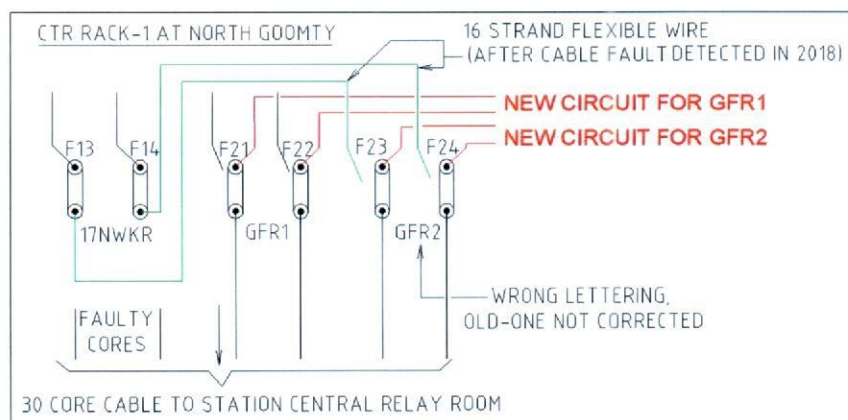

7.2.4.5 The S&T staff realized that they had disconnected the feed coming from the Crossover 17A/B to 17NWKR circuit, and instead connected 3GF RR circuit feed, which is normally available continuously, to 17NWKR circuit; thereby indication feed of Crossover 17A/B was disassociated from the status of the points at site. The following circuit diagram may please be referred in this regard:-

Chandra
28.6.23

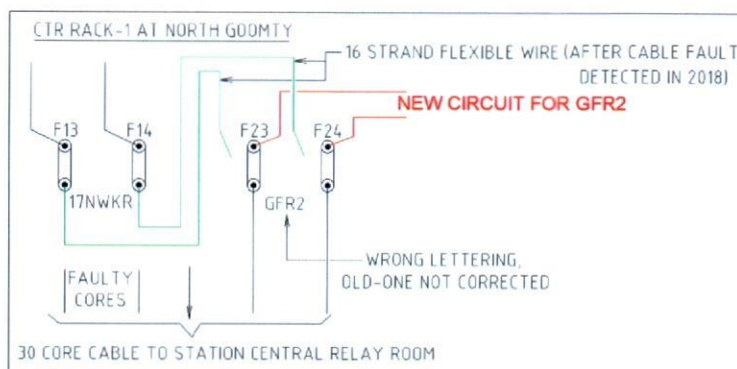

7.2.4.6 After the accident, at 23:28:51:046 hrs, 17NWK1R dropped automatically, picked up and finally dropped at 23:28:58:750 hrs. As per their deposition during the inquiry on 19.6.23, after noticing the mistake in the wiring mentioned above, second GFR (3GF RR) circuit, terminated on F23 & F24, was removed, and the originally released wires for 17NWK1R were connected back. The following circuit diagram may please be referred in this regard:-

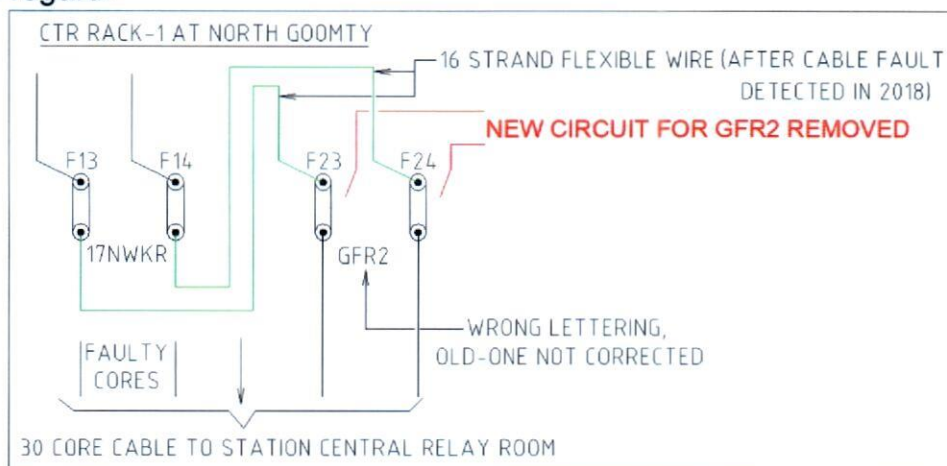

7.2.4.7 The S&T staff expressed that they were misled by following anomalies: -

- Wrong lettering on the terminal F23 & F24 as GFR2 where 17NWK1R circuit was running.
- They had no knowledge of shifting of 17NWK1R circuit from terminals F13 & F14 to terminals F23 & F24; the shifting of this circuit, wherein wires were drawn from back-side of the rack, was not visible from the front side.
- The circuit of LC 79/BLS requires two GFR circuits, viz. 2GF RR, and 3GF RR, whereas for LC 94 only one GFR, viz. 26.2(GF)RR (as designated in the Central Relay Room) was needed which was available at F-21 & F22 terminals. This following extract from the terminal chart of BNBR station [complete terminal chart is enclosed at Annexure (xiv)], and an extract of as made wiring diagram of for ELB-replacement work of LC-94 [diagram at Annexure (xv)] may please be referred in this regard: -

Chodley
28.6.23

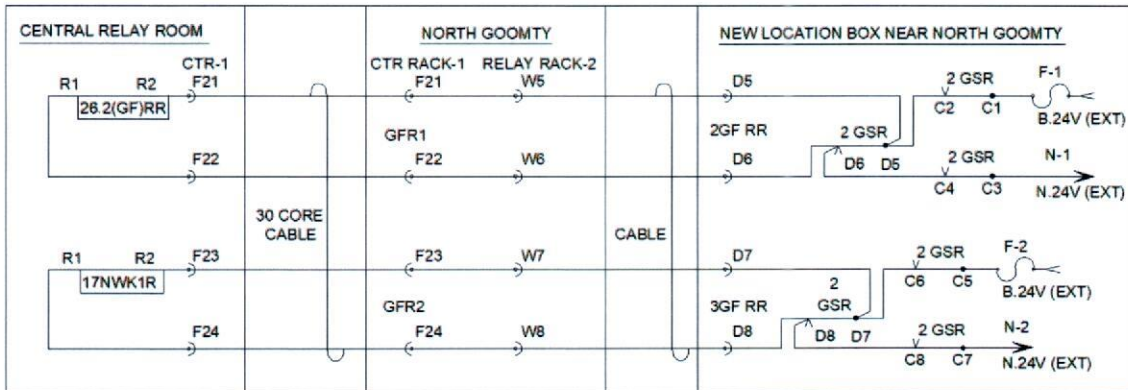
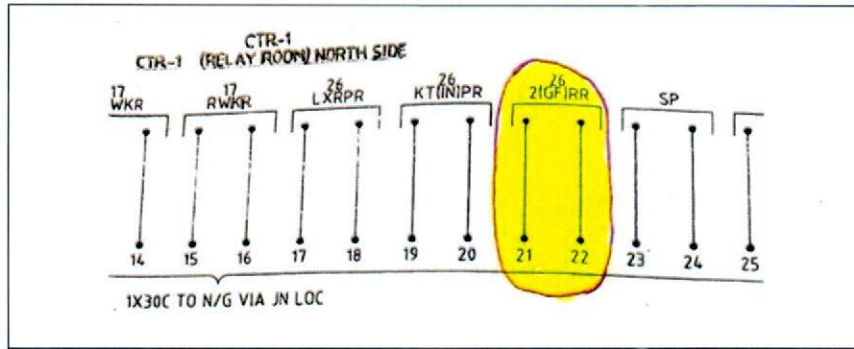

VIII. DISCUSSION

8.1 Explanation of various events based on the analysis done above

8.1.1 The first instance of point failure of the Crossover 17A/B, on 02.06.23, was recorded at 16:20:53:437 hrs, wherein it unexpectedly failed at Normal position.

Explanation: After obtaining disconnection permission at 16:20 hrs, the point failed as the 17NWKR circuit was removed from terminals F23 & F24 on CTR Rack-1 for replacement of GFR2 circuit as per the lettering on these terminals by connecting second GFR (3GF RR) circuit of LC 94 as per the wiring diagram of LC-79/BLS. The following circuit diagrams may please be referred in this regard: -

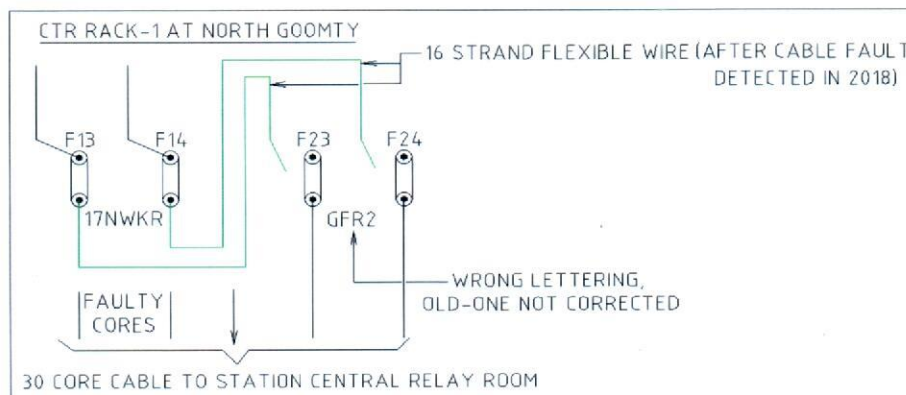

Chowdhury
28.6.23

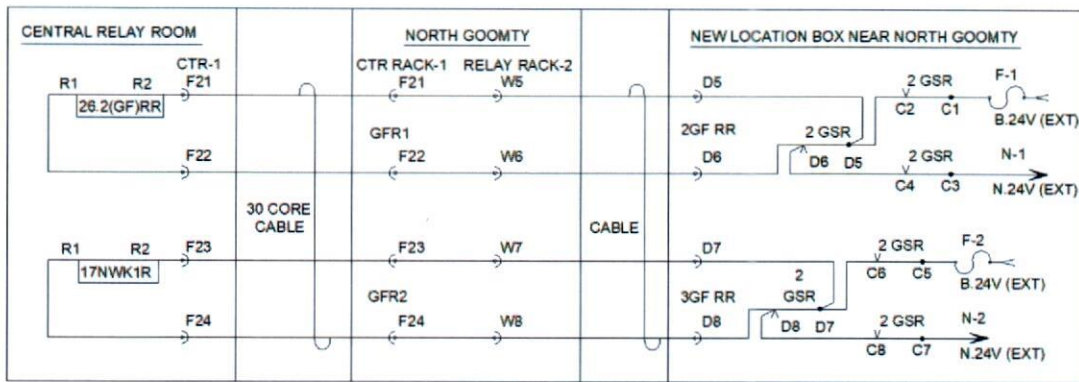

8.1.2 Then SM/BNBR operated the crossover A/B through individual-operation from Normal to Reverse, it took usual time of around 14 seconds, but when he operated the point through individual-operation from Reverse to Normal, it took around 37 seconds and the crossover A/B was set to Normal at 16:22:19:671 hrs – this was unusual.

Explanation: The second GFR (3GF RR, as per the circuit of LC-79/BLS) circuit of LC 94 was connected at 16:22:19:671 hrs at terminals F23 & F24 of CTR Rack-1 of North Goomty, and its feed was extended to the Central Relay Room for 17 NWK1R. Since this feed is normally available, feed to the 17NWK1R was available permanently irrespective of the status (Normal or Reverse) of the Crossover 17A/B. Though the Crossover 17A/B was set to Normal at site, but its indication relay (17NWK1R at Central Relay Room) picked up only after connection of the second GFR circuit at 16:22:19:671 hrs – this explains the reason for time of 37 seconds instead of usual time of 13 to 14 seconds. The following circuit diagrams may please be referred in this regard:-

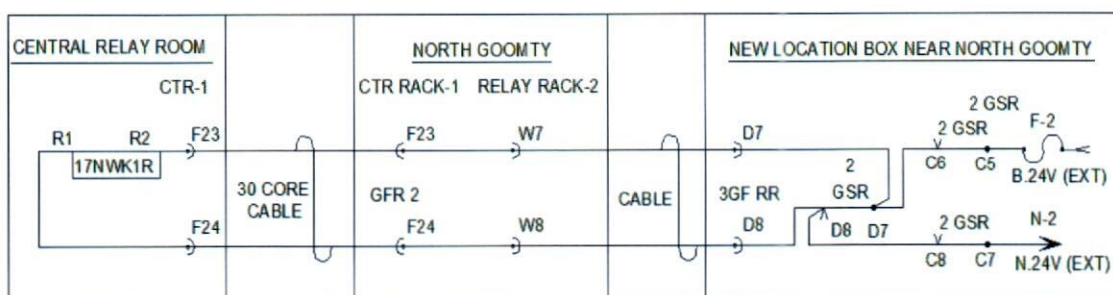
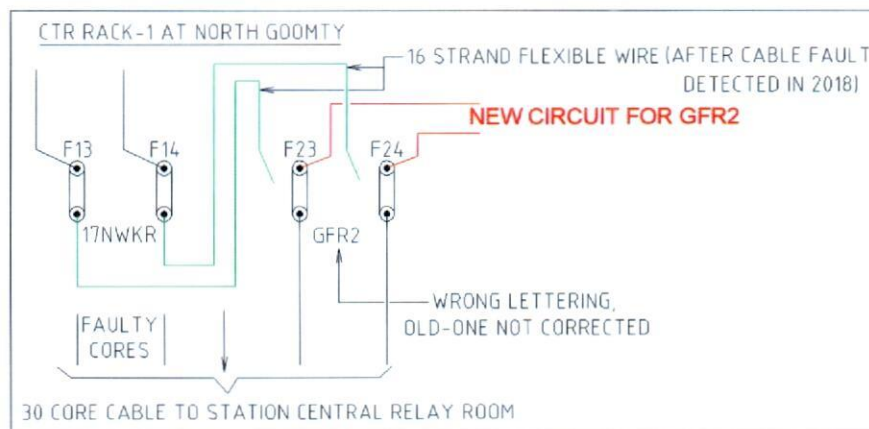

Signature
28.6.23

8.1.3 Further, the Crossover 17A/B was set to Reverse from Normal at 18:14:22:953 hrs through initiation of the Signal Route 1B, i.e., for reception of an UP Goods train on the UP-Loop line. Subsequently, with the same point setting, another Goods train No. N/DDIP was received on the UP-Loop line, and the Route 1B was released at 18:34:52:968 hrs.

Explanation: The design of Point circuit was such that though NWK1R was in picked up state, it was possible to operate the point to Reverse from Normal. As the Point reverse indication circuit was not disturbed, keeping correspondence with actual site condition, 17RWK1R was picked up at the Central Relay Room. As the command relay WRR was in picked up state (which forced dropped relay WNR), 17NWK1R logic got dropped though 17NWK1R was picked up – this allowed 17RWK1R to pick up. Thus, the Signal could be taken off for the UP loop line. The following circuit diagrams may please be referred in this regard:-

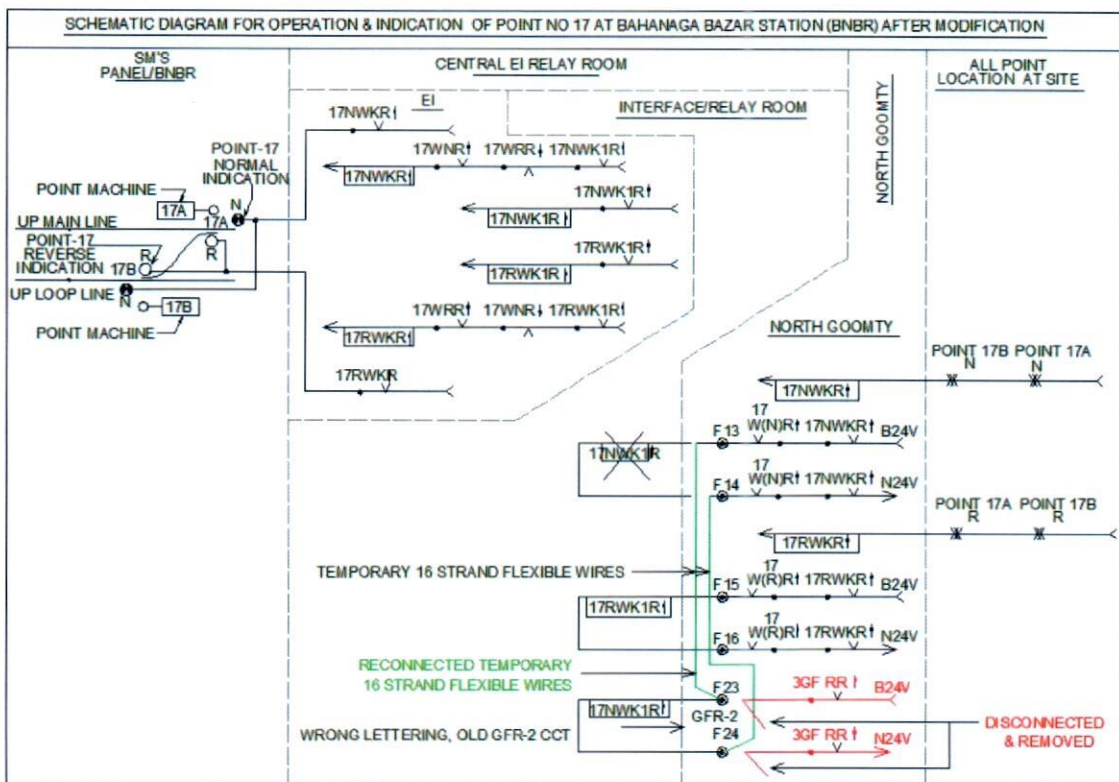

8.1.4 Then, for moving the crossover A/B 17 from Reverse to Normal, individual command was initiated at 18:34:59:265 hrs and its Normal indication on the Panel appeared almost at the same time. This was the most abnormal occurrence as change of status (Reverse to Normal) of a point was supposed to take about 13-14 seconds at BNBR. (ref. para 7.1.2.7).

Explanation:

- i. From 16:22:19:671 hrs, 17NWK1R (in central relay room) was in picked up state with the feed of the second GFR/LC 94, and when the Crossover 17 A/B was set to reverse at 18:14:22:953 hrs, 17RWK1R (in central relay room) picked up in correspondence with the point status at site. It may be observed that both 17 NWK1R, and 17RWK1R were in picked up state from this time. The moment individual command was initiated, the logic bit 17NWK1R in EI picked up immediately as pick up state of 17NWK1R was readily available by false feed [of

Chohan
28.6.23

second GFR circuit (3GF RR)]. The following extract of the schematic diagram of operation and indication of crossover 17A/B [the complete drawing at Annexure (xvi)] may please be referred in this regard:-

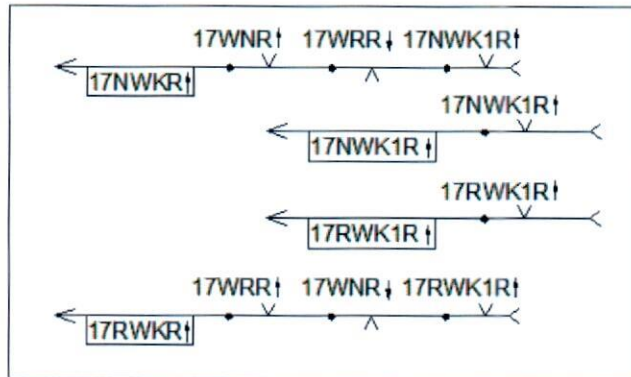

- ii. This abnormal occurrence should have been noticed by SM/BNBR as it occurred during individual operation and he was aware of the normal time required for operation of a point (7 to 15 seconds) which he had mentioned suo motu in the inquiry on 05.06.23. SM/BNBR should have brought this abnormality to the notice of S&T staff working at BNBR, and should not have taken off UP Home Signal for the train 12841.

8.1.5 Even after 18:34:59:265 hrs though in the Panel the Crossover 17 A/B was showing Normal, but at site it was in Reverse state, and accordingly, 17RWK1R was in picked up state in the Central Relay room.

Explanation:

- i. As 17NWK1R was already in picked up state, even after initiation of individual command for operating the point from Reverse to Normal, the command was not extended to the North Goomty and 17W(R)R latch relay remained in picked up state at the North Goomty. Through this latch relay pick up, feed at the North Goomty was extended to 17RWK1R.
- ii. Though both 17NWK1R and 17RWK1R were in picked up state, as the last command logic bit (17WNR) for Normal operation of Crossover 17 A/B was in picked up state, it force-dropped 17WRR and thereby 17RWKR logic bit became low, and allowed 17NWKR to high in EI logic. Due to this, Normal indication of the Crossover 17A/B was available on the Panel even when it was Reverse at site.

The following circuit diagram [also at Annexure (xvi)] may please be referred in this regard:-



Chakraborty
28.6.23

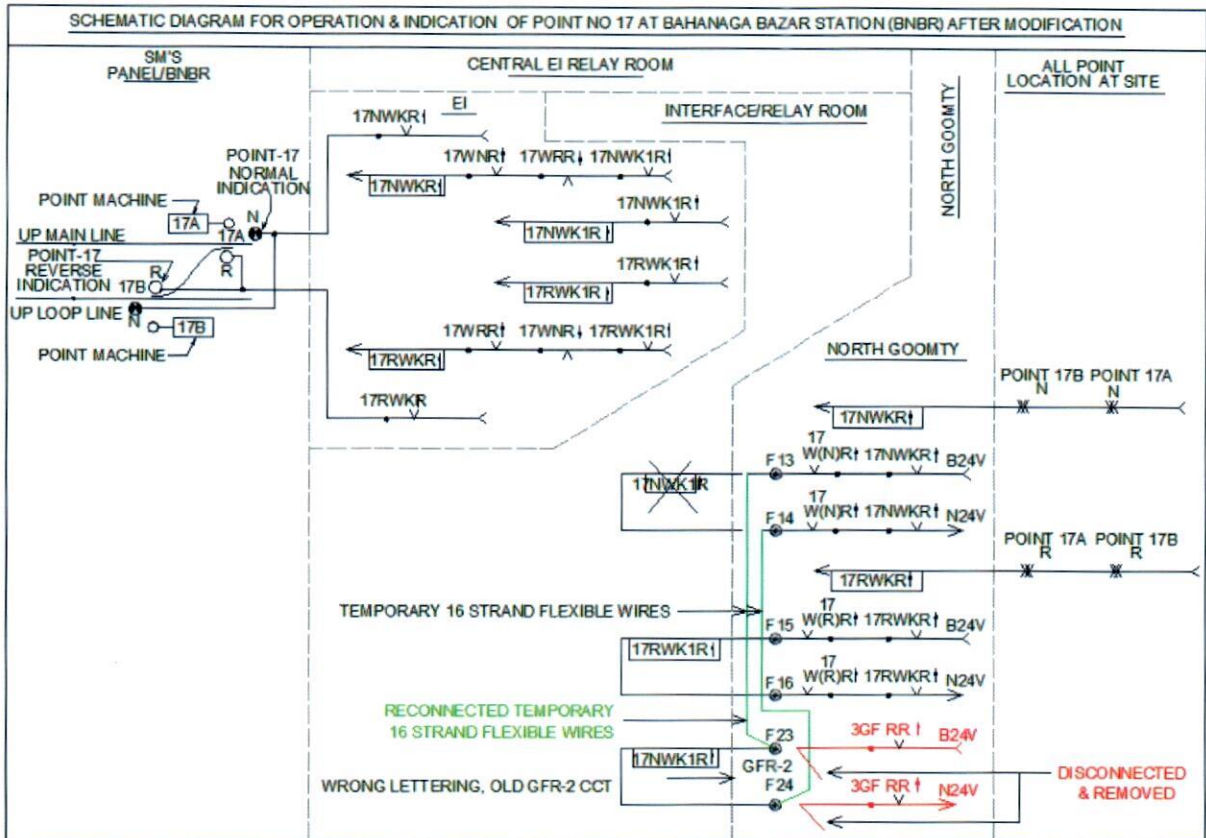

8.1.6 At 18:36:21:125 hrs, 17NWK1R at the Central Room suddenly dropped and again picked up automatically at 18:36:23:500 hrs, i.e., within 2:375 seconds.

Explanation: As 17NWK1R feed was coming from the North Goomty through GFR circuit, this might have occurred due to inadvertent operation / Testing of GFR switch of LC 94.

8.1.7 At 18:36:22:484 hrs, i.e., immediately after dropping of 17NWK1R (as mentioned in para 8.1.6 above), 17RWK1R dropped.

Explanation:

i. Dropping of 17NWK1R for 2:375 seconds (ref. para 8.2.5) caused execution of command (which was initiated to 18:34:59:265 hrs) for operation of the Crossover 17A/B from Reverse to Normal by extending feed to the North Goomty and as a result the latch relay 17W(N)R picked up, and 17W(R)R dropped. As soon as 17W(R)R dropped, feed to 17RWK1R was cut off at the North Goomty. This is explained in the circuit diagram given at Annexure (xvi).

ii. With picking up of 17W(N)R at the North Goomty, 110V supply got extended to the point machine of the point 17B first. As Normal command feed was available for 2:375 seconds only, 110 V supply could not reach to the point machine of the Point 17A because of series operation sequence (17A, after complete operation of 17B).

8.1.8 For taking off UP Home signal to main line for the train 12841, the Signal Route 1A was initiated at 18:52:16:265 hrs. The train passed the Home Signal with Green aspect, entered into UP loop line, and collided with the Goods train No. N/DDIP which was standing there.

Chandray
28.6.23

Explanation:

- i. For taking off the UP Home Signal, the required feeds for 26.2(GF)RR, and 17NWK1R at the Central Relay Room were available from the North Goomty through terminal No. F21 & F22 and F23 & F24 of CTR Rack-1 viz. 2GF RR & 3GF RR circuits respectively as per the ELB circuit of LC 79/BLS which was followed for LC94.
- ii. As 17NWK1R was in picked up state due to false feed, 17NWK1R was in picked up state in EI logic, though the point 17A was in Reverse state at site. As the UP Advanced Starter, and the UP Main line Starter were already taken off, and all favorable logic bits (including 17NWK1R) for taking off UP Home Signal on the UP main line were available, the UP Home Signal could be taken off for the main line.
- iii. It is also seen from the data-logger report that as the train 12841 moved ahead of UP Home Signal, the track circuits dropped in sequence from 1T1, 1T2, 16BT, 17T to 8AXT. UMT1 dropped later on. This also establishes that the train 12841 traversed on the 17A/B crossover with point 17A Reverse.

8.1.9 After the accident, at 23:28:51:046 hrs, 17NWK1R dropped automatically, picked up and finally dropped at 23:28:58:750 hrs.

Explanation: As per the deposition of Shri Amir Khan SSE/Sig/SFO, Shri A.R. Mohanty Tech III/BNBR, Shri Pappu Kumar Tech III/BLS, Shri A.K..Mohanta, SSE/Sig/Incharge, during the inquiry on 19.06.23, after noticing the mistake in the wiring mentioned above, second GFR circuit (3GF RR), terminated on F23 & F24, was removed and the original released wires for 17NWK1R were connected back at North Goomty. Now 17NWK1R restored back in association with the status of Crossover 17 A/B. As point machines of points 17A & 17 B were damaged, the detection-feed from the points was disconnected and that's why 17NWK1R dropped at the North Goomty, and feed to 17NWK1R at the Central Relay Room was also discontinued. This is clear from the circuit diagrams given hereunder [and at Annexure (xvii)]:-

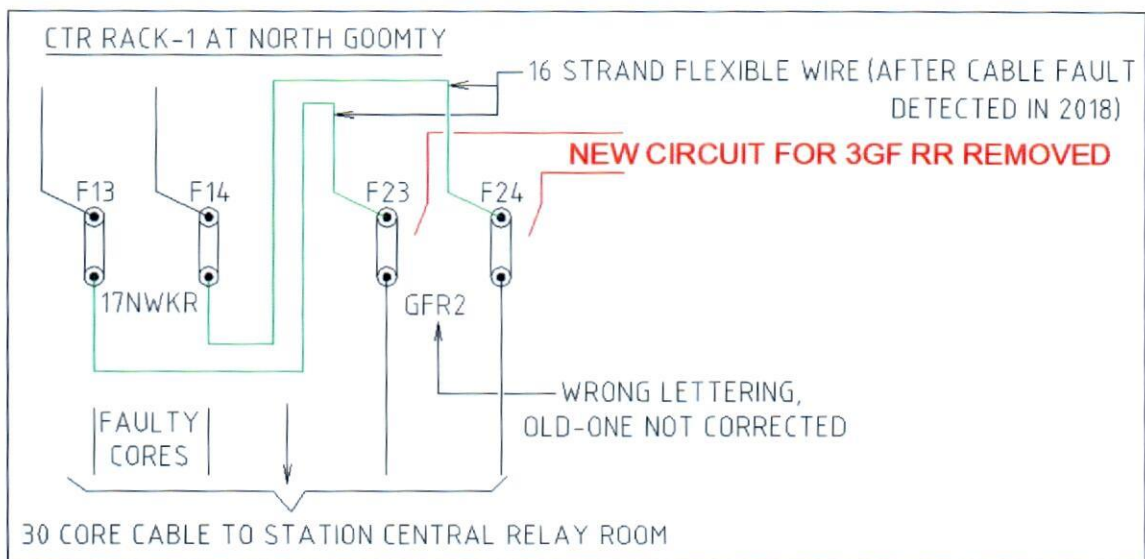

Chodley
28.6.23

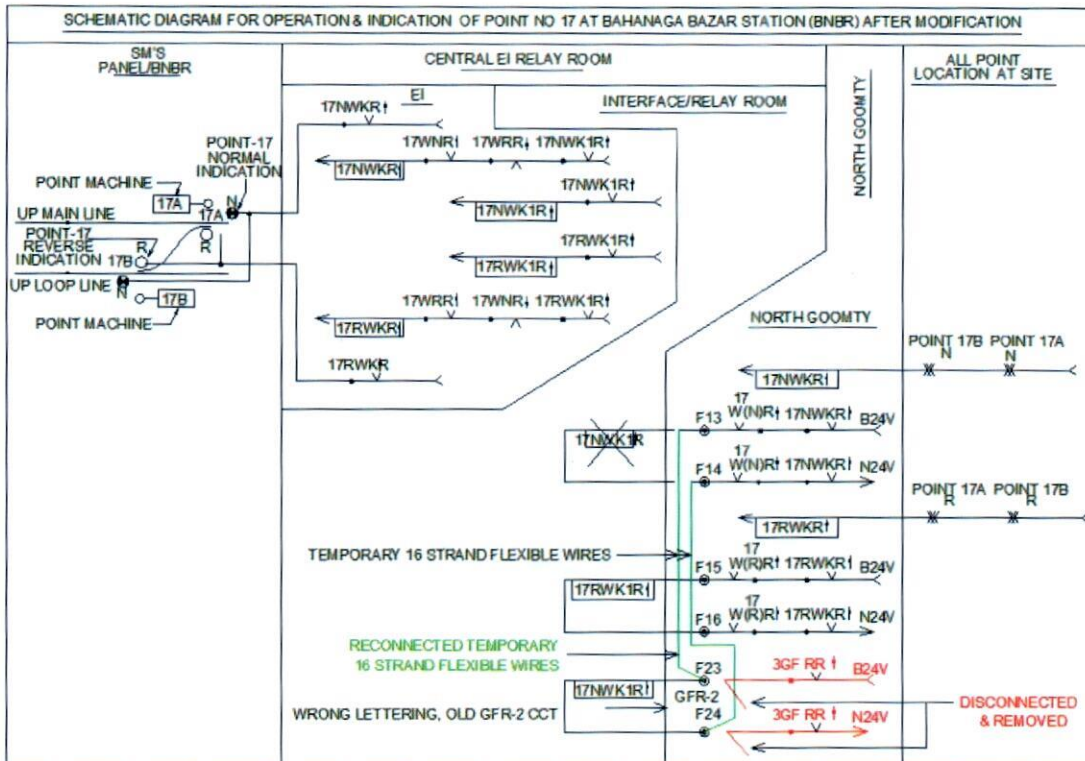

8.2 Cause of the Accident.

- 8.2.1 The speedometer reading of the locomotive of the Train No. 12841 dropping abruptly to zero from 128 kmph indicates a collision, and not a derailment before collision; the derailment before collision would result in reduction in speed. Further it is also clear from the statements of Loco pilot, and Assistant Loco Pilot of the Train 12841 (para 7.2.1), observation of point 17A at site after the accident (para 6.3.1, 6.3.2, and 7.2.2), disposition of loco and coaches of the Train no. 12841 after the accident (para 6.4), and data-logger-report [explanation(iii) of para 8.1.8] that train 12841 traversed on the crossover 17A/B towards the UP-loop line without any derailment, before collision.
- 8.2.2 The locomotive of the Train No. 12841, 37334/WAP7 was not overdue for any Major or Minor schedule inspection; it had also undergone Trip Inspection on 02.06.2023 wherein no safety related defect was existing while turning out the loco after the inspection. After the trip inspection, no defect was logged in the loco logbook by loco crew till the time of accident.
- 8.2.3 No coaches working in the train 12841 and 12864 were overage; they were also not due for any schedule attention.
- 8.2.4 The accident was, thus, not due to any defect in track or the Rolling stock.
- 8.2.5 There were following lapses in execution of the Signalling works, in the past, at BNBR: -
- 8.2.5.1 17 NWKR circuit at North Goomty was shifted from terminals F13 & F14 to the terminals F23 & F24 on the CTR Rack-1 in the year 2018, on account of cable fault, without endorsement in the completion drawing, and also shifting of this circuit was carried out without following standard practice.

Chandra
28.6.23

8.2.5.2 Wrong lettering on the terminals F23 & F24 on the CTR Rack-1 wherein GFR2 was written on the terminals, but 17NWKR circuit was connected after shifting.

8.2.6 There was following lapse in execution of ELB-replacement work:-

8.2.6.1 The circuit for ELB of LC79 of Balasore Station, used for the modification of ELB circuit of LC-94 at BNBR, was not suitable with respect to GFR circuits. In this circuit, requirement of 2GF RR and 3GF RR circuits was mentioned whereas, for LC 94 only one GFR circuit was necessary. There was no approved circuit diagram issued for execution of ELB-replacement work of LC-94 which could prevent this mistake.

8.2.7 The anomalies mentioned in para 8.2.5 and 8.2.6 above misled the S&T staff during the ELB-replacement work of LC-94 which resulted in extension of 3GF RR feed to 17NWKR circuit. The Normal Indication status (17NWKR) of the Crossover 17A/B at the Central Relay Room/ EI logic remained high even when the status of point 17A was in Reverse at site. This resulted in the Train 12841 getting the Home Signal with Green aspect, for run-through movement on the UP main line, with the point 17A set to the loop line; the wrong signalling caused the train to traverse on loop line, and eventual rear-collision with the Goods train (No. N/DDIP) standing there.

8.3 Could the accident have been averted?

8.3.1 Notwithstanding the lapses in signalling work, had the SM/BNBR informed the repeated unusual behavior of the Crossover 17A/B (para 7.1.2.7, and para 8.1.4) to the S&T staff, they could have traced the false feed extending to the EI logic for circuit of Crossover 17A/B.

8.4 Roll of Railway Administration.

8.4.1 There was insignificant involvement at the officer-level in the ELB modification work at BNBR.

8.4.2 **Non-supply of station-specific approved circuit diagram for ELB replacement work of LC-94 at BNBR station**

How the non-supply of this diagram has resulted in such a catastrophe is explained below: -

i. It is learnt from the PCSTE/SER's letter no.S&T/BNBR/CRS REPLY dated 19.6.23 [enclosed at Annexure (xviii)] that the Railway had planned to reuse the pre-wired location box of ELB of LC-79 at Balasore Station (which was closed some time ago) for the ELB-replacement work of LC-94 at BNBR station. Accordingly, Wiring-Diagrams of LC 79 were supplied to the S&T staff at BNBR to carry out the work – this was a wrong step that led to wrong wiring.

ii. At the behest of the Commission, Shri Ajad Sr DSTE/Co./KGP, Shri Amir Khan SSE/Sig/SFO, and Shri Pappu Kumar Tech/III/Sig/BLS prepared and submitted the as-made-wiring-diagram of ELB for LC-94 by modifying the wiring diagram of LC 79/BLS (diagrams enclosed at Annexure (xix).

A glance at the as-made diagrams would reveal that the wiring-diagram of

LC-79 could not be implemented in toto, and a lot of alterations had to be done to suit the site-conditions which should not have been left to the discretion of the field-supervisors.

- iii. From the cable termination diagram of F-Row of the CTR-Rack-1 of the Central Relay Room (connected to the CTR-Rack-1 at the North Goomty), approved on 05.01.2015 (extract shown hereunder), it can be seen that only one GFR circuit was allotted at terminals F21 & F22 of CTR-1 for the purpose of LC-94. Whereas, in the wiring diagram of LC 79, two numbers of GFR circuits were required. Had only one GFR circuit been wired at the corresponding terminals at F21 & F22 at the North Goomty on CTR Rack-1, there would have been no need to alter the circuits at F23 & F24 (where the 17 NWKR circuit was extended from terminals F13, & F14) for the wiring of second GFR circuit (3GF RR as per wiring diagram of LC 79), and thereby this accident could have been prevented.

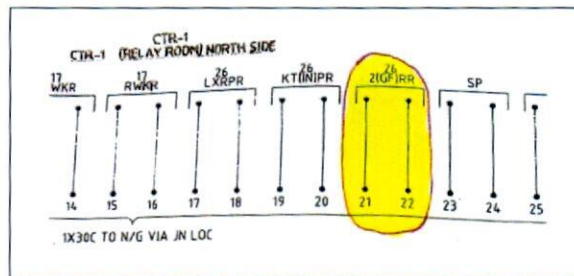

8.4.3 Similar incident in the past

- 8.4.3.1 It is also learnt from the PCSTE/SER's letter (Annexure xviii) that there was a similar incident of mismatch between the intended route set by signals, and actual route taken by train, on 16.05.2022, at BKNM station in Kharagpur Division of South Eastern Railway, on account of wrong wiring and cable fault. Had corrective measures been taken, after this incident, to address the issue of wrong-wiring, the accident at BNBR would not have taken place.

Note: Deployment of a separate team for checking and testing of the modified circuits could be one of such measures.

8.5. Other Matters Brought to Light

- 8.5.1. The initial response to such a disaster should be faster. Railway Board should review the system of disaster-response in the Zonal Railways, and also the co-ordination between the Zonal Railways and various Disaster-Response-Forces (NDRF & SDRF).

IX. CONCLUSION

- 9.1 Having carefully considered all the records submitted, observations made during the site inspection, analysis of the events logged in the data-logger records, and evidences/information received in the inquiry proceedings, I have come to the conclusion that the accident of Train No.12841 (Shalimar-Chennai Coromandal Express), the Goods Train No. N/DDIP and Train No. 12864 (SMVT-Bengaluru-Howrah Express) at Bahanaga Bazar station on 02.06.2023 at about 18:56 hrs in Kharagpur-Ranital section of Kharagpur division in South Eastern Railway,

was a case of the rear-collision of Train No. 12841 with the Goods train (N/DDIP) standing on the Up loop line(common loop) of the Station. The last two coaches of Train No. 12864, which was passing on the Down Main line of the station at the same time, were hit by the derailed coaches of Train No.12841, and capsized.

The rear-collision was due to the lapses in the signalling-circuit-alteration carried out at the North Signal Goomty (of the station) in the past, and during the execution of the signalling work related to replacement of Electric Lifting Barrier for level crossing gate no. 94 at the Station. These lapses resulted in wrong signalling to the Train No. 12841 wherein the UP Home Signal indicated Green aspect for run-through movement on the UP main line of the station, but the crossover connecting the Up main line to the Up loop line (crossover 17A/B) was set to the UP loop line; the wrong signalling resulted in the Train No.12841 traversing on the UP loop line, and eventual rear-collision with the Goods train (No. N/DDIP) standing there.

X. RESPONSIBILITY

Lapses at multiple levels in the S&T Department were responsible for this accident.

XI. REMARKS AND RECOMMENDATIONS

- 11.1 A drive should be launched to update the Completion signalling wiring diagrams, other documents (SIP, RCC, SWRD, Panel/VDU diagrams etc.), and lettering of signalling circuits at site.
- 11.2 Standard practices should be followed for carrying out signalling-modification work.
- 11.3 Before taking up modification of the existing signalling circuits, functional tests of the existing circuits, under alteration, should be carried out to ensure that actual circuits are in accordance with the completion drawings.
- 11.4 Any alteration to signalling circuits should be carried out with an approved circuit diagram, and in presence of an Officer.
- 11.5 A separate team should be deployed for checking and testing of modified signalling circuits and functions before restoration/ reconnection of the work.
- 11.6 A competency certificate should be issued after a rigorous practical training for carrying out signalling modification works. Both the Execution, and Checking & Testing of Signalling -modification works should be done by staff in possession of this competency certificate.
- 11.7 In the event of a condition wherein pick up of both 'Normal', and 'Reverse' indication relays is detected for a point, all signal movement over that point should be prevented. In case of EI, this should be registered as fault condition, and the system should shut down automatically.
- 11.8 If the status of a point indication relay (physical relay) is 'Normal', then the command for operation of the point from Reverse to Normal should not generate; and vice-versa.

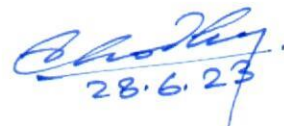
28.6.23

- 11.9 Point detection circuits should be carried in a separate cable for each Point/Crossover without any intermediate termination.
- 11.10 The point switch groups should be eliminated in EI installations.
- 11.11 Provision should be made for separate logging of physical relays in the Station data-logger.
- 11.12 RTU should be provided at end-goomties for logging of digital and analog inputs for ensuring end to end matching of status of gears.
- 11.13 The Station Masters should be made aware of possible faulty conditions of EI system that could be detected through indications on the Panel; these should also be listed and incorporated in the SWR.
- 11.14 As a long-term measure, Signalling functions/gears should be directly connected to EI, through OFC, eliminating intermediate relays.



28.6.23

(A.M. Chowdhary)
Commissioner of Railway Safety
South Eastern Circle, Kolkata